

200W LED Beam Moving Head With Light Ring

200BEAM

Light Source

Light Source: 200W LED & 36pcsx0.5W RGB SMD LED
Life expectancy: 6,000 hours

Optical System

Advanced optical system ensure clear, sharp image quality
High-efficiency optical system
Beam angle: 0-4°

Control & Program

4-button touch panel
Display: Color display
Protocols: DMX512, Sound Active, Automatic, Master/Slave, RDM
DMX modes: 2
Control channels: 17, 20 Channels
Pan/Tilt resolution: 16-bit
Firmware Upgrade via DMX link & USB

PAN & TILT

Pan movement: 540°
Tilt movement: 270°
Automatic Pan/Tilt position correction

Static Gobos

1x static gobo wheel with 15 gobos plus open

Color Wheel

1x color wheel with 14 colors plus white bidirectional rainbow effect

Prism

Equipped with 1 8-prism, 24 prism, and tower mirror, the 16 prism can rotate and overlap with the tower mirror or 8 prism in both directions, also have atomized Colorful Plate

Prism

Equipped with 1 8-prism, 16 prism, and tower mirror, the 16 prism can rotate and overlap with the tower mirror or 8 prism in both directions

Electrical & Connectors

Power supply with electronic auto-ranging
Input voltage range: 100-240V~ 50/60Hz
Power consumption: 285W
power connector in/out
Data in/out: 3-pin or 5-pin XLR
Carton Dimensions: 490x340x620mm
Weight: 18kg



Size mm(in)

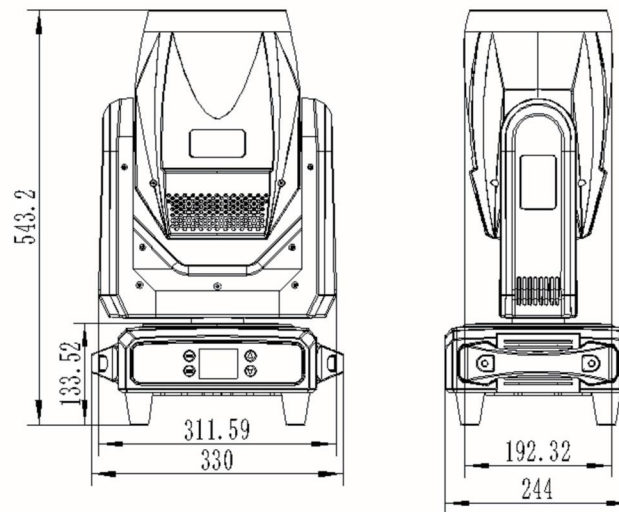

Functional Effect

Color Wheel



Static Gobo Wheel

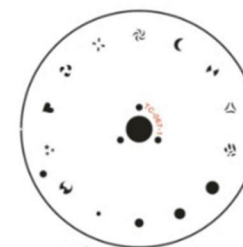

Local Details

